

Immersion Separator NA35-110

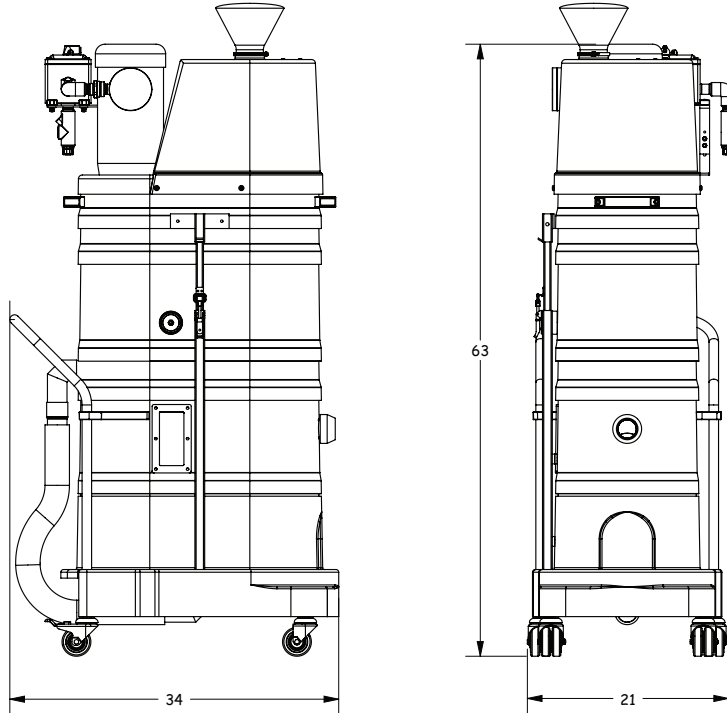

Accessory Package, 151510DEX, Includes: 1.5" x 10' static conductive, urethane hose w/molded carbon impregnated cuffs; 54" aluminum shaft wand; 11" aluminum crevice tool, 3" round brush w/nylon bristles; 14", metal floor brush w/anti-static bristles, 2" x 1.5" reducer.

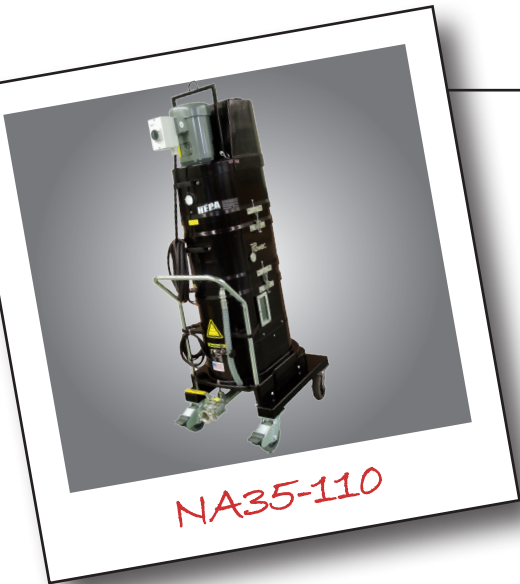

NA35-110 Standard Specifications

- Single Phase, TEFC, 1.5Hp, 110 V, 14 Amp
- 5.5 Hg", 135 CFM
- 44 ft² hydrophobic filter
- 9 Gallon water bath
- Counter balanced with 3" heavy duty conductive casters
- External site glass
- External liquid capacity site gauge
- Carbon impregnated compression cast composite housing
- Anti-static 10⁻⁶ Ohms
- Stainless steel de-misting pad
- "Ruwac Exclusive" Internal dispersal screen system

Base Price¹: NA35-110 - Call for Pricing

ADDER	DESCRIPTION
D-NA	Explosion Proof HEPA Module w/Extended Caster Assembly w/Antistatic Casters ¹
10007147	Replacement Hydrophobic Filters w/SS end caps ^{FIL3}
1560OHDEX	Overhead Cleaning Accessory Kit ^{PKG}
-25	Optional - increase hose length to 25' ^{HOS2}
EX-M	Explosion Proof motor and switch ¹