

WORKHORSE Silo

CONTINUOUS DUTY SILO VACUUMS

**ULTRA RUGGED DESIGN WITH AN
INCREASED COLLECTION CAPACITY**

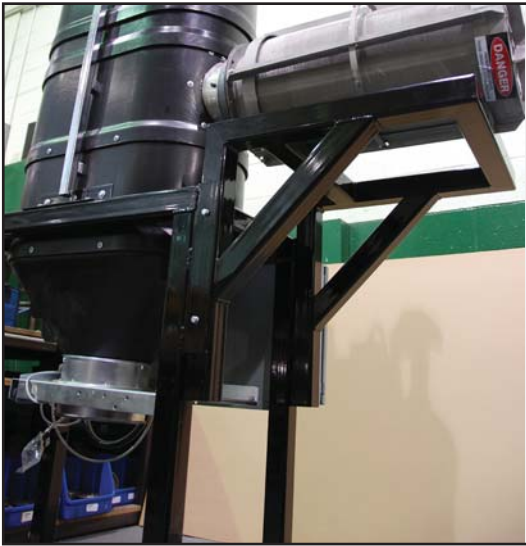

Ideal for:

- » Point of source extraction
- » Industrial shop maintenance
- » Multiple operators
- » Central systems
- » Removal of materials such as:
 - Large chips and debris
 - Combustible dust
 - Abrasive materials

**Explosion Proof
Models Available**

- Continuous duty operation
- Ultra rugged design featuring compression cast housing
- 30 gallon drum capacity
- Industry-leading MicroClean filtration
- Fully customizable filter, disposal and frame

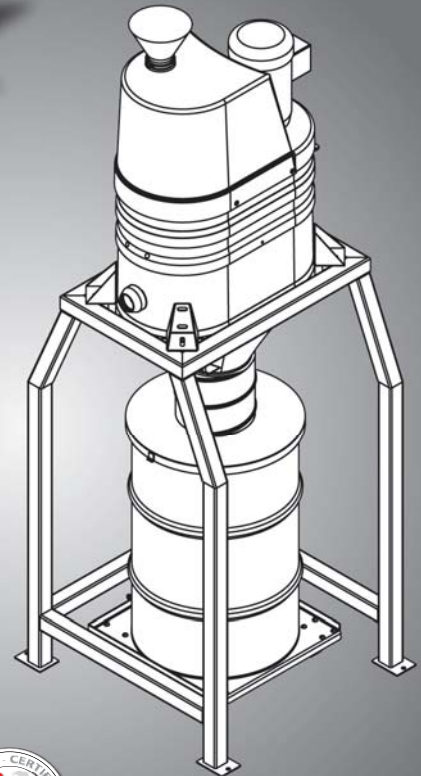

MADE IN



THE USA



Ruwac

We vacuum everything.

WorkDustFree.com

Call: (704) 752-7944



WORKHORSE Silo

CONTINUOUS DUTY SILO VACUUMS

The Workhorse Series silo vacuum features an ultra rugged design and enough suction to power a central vacuum system. Continuous duty operation makes it ideal for point of source extraction, the cleaning of combustible dust, explosive materials, large chips and debris alongside industrial shop maintenance. Fully grounded and sealed to protect against static build-up, each silo is built with durable and dependable compression cast composite housing that's covered by a lifetime guarantee. It also includes a 30 gallon drum for increased collection capacity. Combined with Ruwac's industry-leading MicroClean filtration, optional HEPA and drum upgrades, The Workhorse Series silo vacuum is one of the toughest silo vacuum systems available on the market!

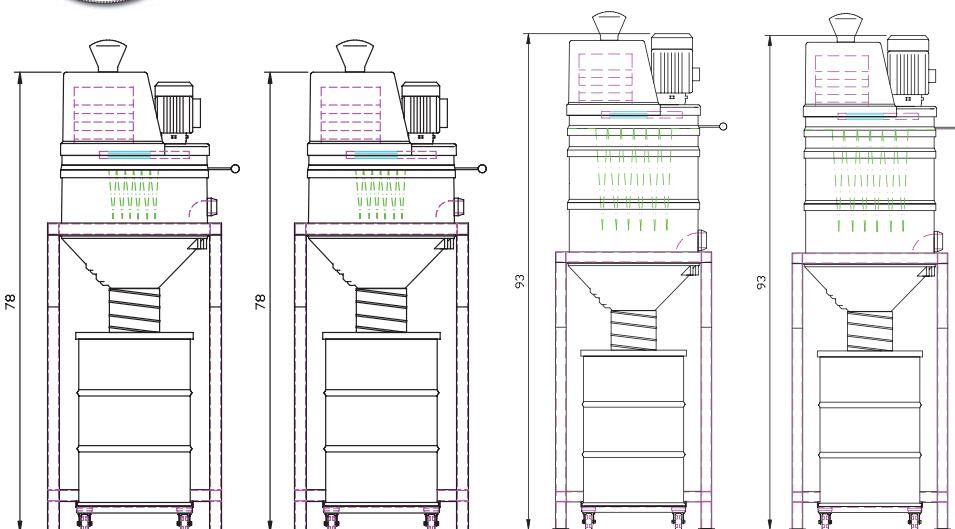

SV-D11	SV-D12	SV-D14	SV-D17
180 CFM	180 CFM	300 CFM	288 CFM
5 Hg"	5.7 Hg"	6.2 Hg"	8.2 Hg"
230 / 460 V	230 / 460 V	230 / 460 V	230 / 460 V
2 Hp	3 Hp	5 Hp	10 Hp
13 Sq. Ft. filter	13 Sq. Ft. filter	28 Sq. Ft. filter	28 Sq. Ft. filter

SILO FEATURES and ADDITIONAL OPTIONS

- MICROCLEAN FILTRATION (Standard)**
- 99.99% efficient at 0.5 microns
 - Proven pleated design
 - 3-year filter guarantee



FILTER ADD-ONS (Alternative)

- HEPA: 99.99% efficient at 0.3 microns
- ULPA: 99.99% efficient at 0.1 microns
- Activated Carbon Modules



FILTER CLEANING

- Manual shaker filter (Standard)
- Reverse pulse filter (Alternative)
- Motorized shakers (Alternative)

DISPOSAL

- 8" Direct drumfill system w/ 30 gallon drum (Standard)
- Optional 55 gallon drum upgrade
- Optional tipping drum w/ 6" casters
- Optional equalizer kit for internal bagging
- Continuous discharge rotary (Alternative)
- Pneumatic air locks (Alternative)
- Double dump valves (Alternative)

FRAME

- Heavy duty frame (Standard)
- Wall mount optional frame
- Custom frames to fit any configuration
- Contact us today for more info!

